

Rapiscan 632XR

Rapiscan
systems

An OSI Systems Company

BAGGAGE AND PARCEL INSPECTION

Pallet and Cargo Screening

Heavy Duty Conveyor

Network Enabled

Cost Effective



With a 1,500 mm (59.1 inches) wide x 1,650 mm (65.0 inches) high tunnel opening and a heavy-duty roller conveyor, the **Rapiscan 632XR** is designed to inspect pallets and other large cargo weighing up to 3,000 Kgs (6,600 pounds), and provide a horizontal view of the pallet. An optional belt conveyor is also available.

Like all systems in the 600 series family of X-ray scanning solutions, the Rapiscan 632XR is built on a standardized platform that makes it easy to install and maintain, and comes with features such as dual-energy detection, a streamlined, ergonomic design, and Rapiscan's feature-rich OS600 system software.

CUSTOMER SUPPORT SERVICES

Our team is dedicated to providing a prompt, effective and personalized response that exceeds your expectations. With spare parts inventory and skilled technicians all over the world, you can be certain Rapiscan Systems will always be prepared with a solution to address your requirements. By measuring response time, parts delivery and support status, our team embraces a customer focused philosophy to ensure continual improvement in customer support, products and services.

Feature & Option Highlights

OS600 System Software:

Rapiscan's OS600 software provides an intuitive Graphical User Interface with improved image quality as well as advanced networking capabilities.

Threat Image Projection (TIP): TIP inserts digital threat images at configurable frequencies into the regular flow of bags. TIP is the preferred operator performance measurement and training method used by regulatory agencies worldwide.

Threat Image Projection Network (TIPNET): TIPNET is a secure, high speed network that links all TIP enabled systems to a central station.

Target: Target™ is Rapiscan's innovative automatic threat and contraband detection technology. Target's software algorithms search X-ray images for targeted materials by analyzing the mass, size and atomic number of items in the image.

Operator Training Program (OTP): OTP is an easy-to-use software application that helps users learn key system features and functionality.

Density Threshold Alert (DTA): DTA generates a visible alarm when an imaged object exceeds a user-specified density threshold.



ONE COMPANY - TOTAL SECURITY

BAGGAGE AND PARCEL INSPECTION

PHYSICAL SPECIFICATIONS

Dimensions: Length: 6,492 mm (255.6 in.)
Height: 2,042 mm (80.4 in.)
Width: 2,874 mm (113.1 in.)
Tunnel Size: 1,500 mm (W) x 1,650 mm (H) (59.1 x 65.0 in.)
Conveyor Speed: 0.20 m/sec (39.4 ft./min)
Conveyor Max Load: 3,000 Kg (6,614 lbs) evenly distributed
Conveyor Height: 285 mm (11.2 in.)
Approx Weight: Net: 2,154 Kg (4,749 lbs)
System Power: 115/230 VAC +/- 10% / 60/50Hz

X-RAY GENERATOR AND IMAGE PERFORMANCE

Steel Penetration: 28mm guaranteed; 30mm typical
Wire Resolution: 38 AWG guaranteed, 40 AWG typical
Material Separation: Low Z, Medium Z, High Z to 0.5 Z accuracy
Generator Cooling: Sealed oil bath with forced air
Anode Voltage: Operating at 150kV
Tube Current: 1.5 mA
Orientation: Horizontal

OPERATING ENVIRONMENT

Storage Temperature: -20°C to 50°C
Operating Temperature: 0°C to 40°C
Relative Humidity: 5 to 95% non-condensing

HEALTH & SAFETY

All Rapiscan Systems products comply with applicable international health and safety regulations including USA FDA X-ray systems (Federal Standard 21CFR 1020.40) and Health and Safety at Work Act 1974-section 6, Amended by the Consumer Protection Act 1987. Maximum leakage radiation less than 0.1mR/hr (1µ Sv/hr) in contact with outer panels. (FDA Compliance applies to systems configured with an operator presence device.)

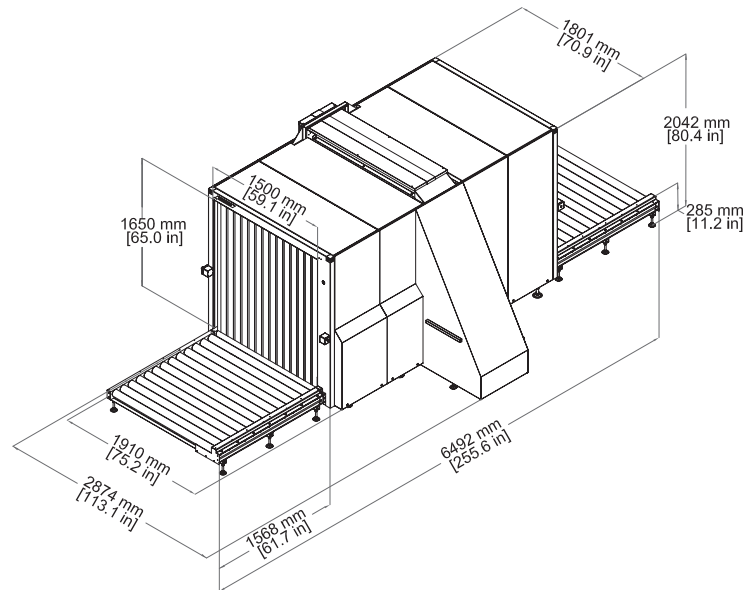

STANDARD FEATURES	OPTIONS AND ACCESSORIES
Multi Energy Imaging (4 Color)	Threat Image Projection (TIP)
Crystal Clear	Target
Black and White Viewing	Interactive Target
Organic / Inorganic Stripping	Density Threshold Alert (DTA)
Inverse Video	Operator Training Program (OTP)
High Penetration	Manual Scan
Variable Edge Enhancement	Automatic Image Archiving
Variable Color Stripping	Threat Image Projection Network (TIPNET)
Variable Gamma	Network Display Station (NDS)
Variable Density Zoom	Smart Card Login
Zoom (to 64x)	Belt Conveyor
View Previous Bag	Power Conditioner
Manual Image Archive	Foot-mat
Configurable Image Processing Keys	Conveyor Accessories
Baggage Counter	CRT Color Monitor, Non-flicker
Date / Time Display	
High Penetration X-Ray Generator	
Search Indicator	
UPS (Uninterrupted Power Supply)	
Remote Workstation	
Flat Panel LCD Monitor	

SAFETY Act Certified



ISO 9001:2000 Certified

With continual development of our products Rapiscan Systems reserves the right to amend specifications without notice.

www.rapiscansystems.com • sales@rapiscansystems.com

AMERICAS, CARIBBEAN

2805 Columbia Street
Torrance, California 90503
UNITED STATES OF AMERICA
Tel: +1 310-978-1457
Fax: +1 310-349-2491

EUROPE, MIDDLE EAST, AFRICA

X-Ray House
Bonehurst Road
Salfords
Surrey RH1 5GG
UNITED KINGDOM
Tel: +44 (0) 870-7774301
Fax: +44 (0) 870-7774302

ASIA

240 Macpherson Road
#07-03 Pines Industrial Building
Singapore 348574
SINGAPORE
Tel: +65-6743-9913
Fax: +65-6743-9915

AUSTRALIA

Rapiscan House
4 Ross Street
South Melbourne Victoria
Australia 3205
AUSTRALIA
Tel: +61 3 9929 4600
Fax: +61 3 9929 4655

distributor stamp