

Rapiscan 622XR

Rapiscan
systems

An OSI Systems Company

BAGGAGE AND PARCEL INSPECTION

Large Baggage and Parcel Screening

Adjustable Control Panel

Network Enabled

Performance and Value



The **Rapiscan 622XR** offers customers both high performance threat detection and lower total cost of ownership. The 622XR has a 750 mm (29.5 inches) wide by 550 mm (21.7 inches) high tunnel opening, which means it can accommodate a range of parcel and baggage sizes. The 622XR's innovative design allows for bidirectional operation, while its dual-energy detection provides automatic color coding of materials so that screeners can identify the material composition of a scanned object. In addition, it offers options like an adjustable control panel stand and swing-open, easy-access panels.

Like all systems in the 600 series family of X-ray scanning solutions, the Rapiscan 622XR is built on a standardized platform that makes it easy to install and maintain, and comes with features such as dual-energy detection, a streamlined, ergonomic design, and Rapiscan's feature-rich OS600 system software.

CUSTOMER SUPPORT SERVICES

Our team is dedicated to providing a prompt, effective and personalized response that exceeds your expectations. With spare parts inventory and skilled technicians all over the world, you can be certain Rapiscan Systems will always be prepared with a solution to address your requirements. By measuring response time, parts delivery and support status, our team embraces a customer focused philosophy to ensure continual improvement in customer support, products and services.



Feature & Option Highlights

OS600 System Software:

Rapiscan's OS600 software provides an intuitive Graphical User Interface with improved image quality as well as advanced networking capabilities.

Threat Image Projection (TIP): TIP inserts digital threat images at configurable frequencies into the regular flow of bags. TIP is the preferred operator performance measurement and training method used by regulatory agencies worldwide.

Threat Image Projection Network (TIPNET): TIPNET is a secure, high speed network that links all TIP enabled systems to a central station.

Target: Target™ is Rapiscan's innovative automatic threat and contraband detection technology. Target's software algorithms search X-ray images for targeted materials by analyzing the mass, size and atomic number of items in the image.

Operator Training Program (OTP): OTP is an easy-to-use software application that helps users learn key system features and functionality.

Density Threshold Alert (DTA): DTA generates a visible alarm when an imaged object exceeds a user-specified density threshold.

BAGGAGE AND PARCEL INSPECTION

PHYSICAL SPECIFICATIONS

Dimensions: Length: 2,282 mm (89.9 in.)
Height: 1,467 mm (57.8 in.) *excluding monitor*
Width: 1,030 mm (40.6 in.)

Tunnel Size: 750 mm (W) x 550 mm (H) (29.5 x 21.7 in.)

Conveyor Speed: 0.20 m/sec (39.4 ft./min)

Conveyor Max Load: 165 Kg (364 lbs)

Conveyor Height: 785 mm (30.9 in.)

Approx Weight: Net: 620 Kg (1,366 lbs)

System Power: 115/230 VAC +/- 10% / 60/50Hz

X-RAY GENERATOR AND IMAGE PERFORMANCE

Steel Penetration: 28mm guaranteed; 30mm typical

Wire Resolution: 38 AWG guaranteed; 40 AWG typical

Material Separation: Low Z, Medium Z, High Z to 0.5 Z accuracy

Generator Cooling: Sealed oil bath with forced air

Anode Voltage: Operating at 140kV

Tube Current: 0.7 mA

Orientation: Vertically Upward

HIGH PENETRATION X-RAY GENERATOR OPTION

Steel Penetration: 35mm guaranteed; 40mm typical

Wire Resolution: 38 AWG guaranteed; 40 AWG typical

Anode Voltage: Operating at 160kV

Tube Current: 1.0 mA

OPERATING ENVIRONMENT

Storage Temperature: -20°C to 50°C

Operating Temperature: 0°C to 40°C

Relative Humidity: 5 to 95% non-condensing

HEALTH & SAFETY

All All Rapiscan Systems products comply with applicable international health and safety regulations including USA FDA X-ray systems (Federal Standard 21CFR 1020.40) and Health and Safety at Work Act 1974-section 6, Amended by the Consumer Protection Act 1987. Maximum leakage radiation less than 0.1mR/hr (1µ Sv/hr) in contact with outer panels. (FDA Compliance applies to systems configured with an operator presence device.)

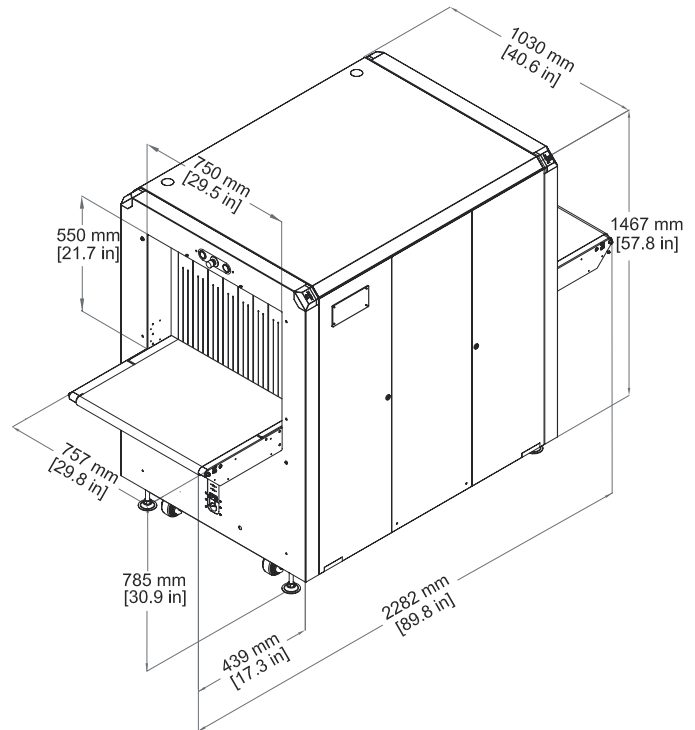

STANDARD FEATURES	OPTIONS AND ACCESSORIES
Multi Energy Imaging (4 Color)	Threat Image Projection (TIP)
Crystal Clear	Target
Black and White Viewing	Interactive Target
Organic / Inorganic Stripping	Density Threshold Alert (DTA)
Inverse Video	Operator Training Program (OTP)
High Penetration	Manual Scan
Variable Edge Enhancement	Automatic Image Archiving
Variable Color Stripping	Threat Image Projection Network (TIPNET)
Variable Gamma	Network Display Station (NDS)
Variable Density Zoom	Smart Card Login
Zoom (to 64x)	High Penetration X-Ray Generator
View Previous Bag	Power Conditioner
Manual Image Archive	Foot-mat
Configurable Image Processing Keys	Adjustable Height Lift and Tilt Stand
Baggage Counter	Remote Workstation
Date / Time Display	Conveyor Accessories
Search Indicator	CRT Color Monitor, Non-flicker
UPS (Uninterrupted Power Supply)	
Flat Panel LCD Monitor	

SAFETY Act Certified



ISO 9001:2000 Certified

With continual development of our products Rapiscan Systems reserves the right to amend specifications without notice.

www.rapiscansystems.com • sales@rapiscansystems.com

AMERICAS, CARIBBEAN

2805 Columbia Street
Torrance, California 90503
UNITED STATES OF AMERICA
Tel: +1 310-978-1457
Fax: +1 310-349-2491

EUROPE, MIDDLE EAST, AFRICA

X-Ray House
Bonehurst Road
Salfords
Surrey RH1 5GG
UNITED KINGDOM
Tel: +44 (0) 870-7774301
Fax: +44 (0) 870-7774302

ASIA

240 Macpherson Road
#07-03 Pines Industrial Building
Singapore 348574
SINGAPORE
Tel: +65-6743-9913
Fax: +65-6743-9915

AUSTRALIA

Rapiscan House
4 Ross Street
South Melbourne Victoria
Australia 3205
AUSTRALIA
Tel: +61 3 9929 4600
Fax: +61 3 9929 4655

distributor stamp